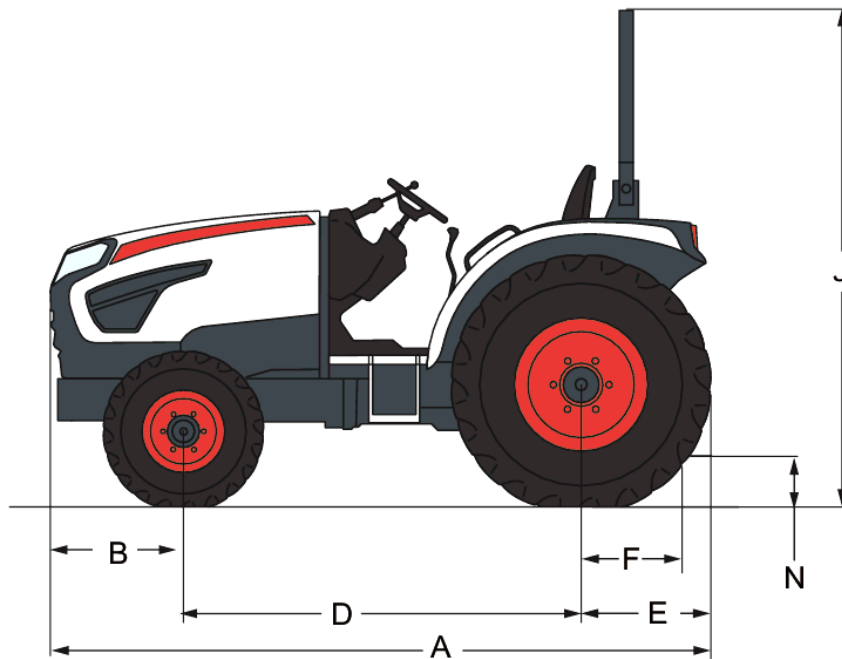
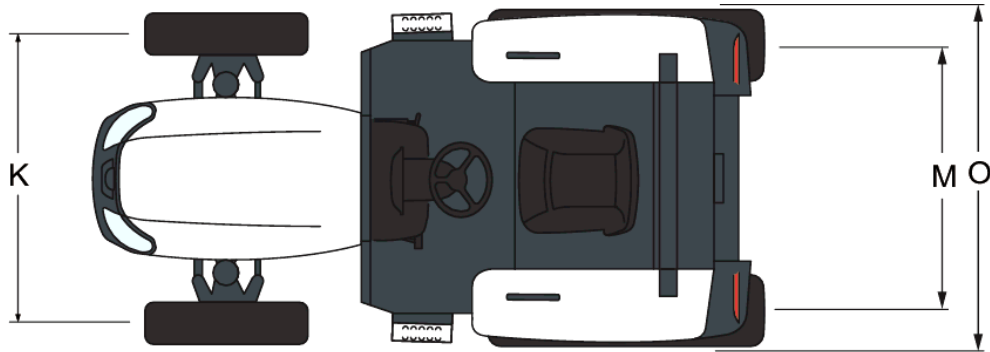

Dimensions

(D) Wheelbase	1808.0 mm
(J) Overall height	2474.0 mm
(K) Front track width	1251.0 mm
(M) Rear track width	1254.0 mm
(N) Ground Clearance under the Rear Axle (Hitch Frame)	387.0 mm
(O) Overall Width	1702.0 mm
(Wt.)Weight with ROPS	1619 kg

Standard Features

- 4 Wheel Drive
- Mechanical differential lock
- Hydrostatic Power Steering
- Tilt Steering
- Quick turn
- Rear folding ROPS
- Rear PTO, Independent
- PTO Cover
- Stationary PTO
- Auto PTO
- Draft Control
- Rear remote hydraulics, two pair (4 port)
- Front Hitch
- Fuel Heater
- PTO Cruise
- 7 Pin Socket
- 12V Aux
- Beacon Ready Wiring
- Horn
- Rear View Mirror
- Cup holder
- OPC
- SMV sign
- Floor mat
- Toolbox

Engine

Engine type	3 cylinder, water cooled, 4 cycle, Vertical In-Line Common Rail Direct Injection (CRDI)
Fuel	Diesel
Displacement	1.80 L
Max Torque	166.0 Nm
Gross Power (ECE-R120)	50.3 HP
Net Power	48.3 HP
Rated revolution	2600.0 RPM
Alternator	12V/75A
Air Cleaner	Dry type, replaceable
Fuel tank	45.00 L

Drive Train

Transmission	Manual, 16F/16R
Shuttle Type	H-Shuttle
Hand clutch	Standard
Max. Travelling Speed Forward	32.8 km/h
Max. Travelling Speed Reverse	32.0 km/h
Steering	Hydrostatic Power Steering
Turning radius(w/brake)	2640.0 mm
Brake type	Wet disc type
Mechanical differential lock	Rear Std.
Front wheel drive system	Hydraulic multi disc Clutch

Hydraulic System

Implement Pump	36.40 L/min
Power steering pump	18.70 L/min
Total hydraulic flow	55.10 L/min
No.of Std. remote valve's ports (Rear)	Std. (4 port)

Hitch

Check Link type (Manual Transmission)	Turn-buckle
Top Link type	Turn-buckle
Lift rod type	Turn-buckle
@lift point (Horizontal position)	1707
Lift capacity at lift point	1417 kg
Lift capacity at 610 mm (24 in.) behind lift point	1467 kg
Drawbar type	Bar(Clevis)
Max. Drawbar vertical load	750 kg
Max. Trailer loading weight	4300 kg

PTO

Max PTO Power	40.9 HP
Rear PTO	SAE 1-3/8, 6 Spline
Rear PTO type	Independent
Rear PTO speed	540/540E RPM

Capacity (Other)

Engine crankcase(included filter)	7.40 L
Coolant	3.30 L
Transmission case	43.00 L
Support of front axle	5.60 L

Tires

Agriculture Tires	Front: 8-16 R1 / Rear: 13.6-24 R1
Turf tires	Front: 29x12.5-15NHS R3 / Rear: 44x18.0-20 R3
Industrial Tires	Front: 10-16.5 (124 A2) / Rear: 17.5L-24 R4