

TR60-310 V R2-Series

Telescopic
Specifications

Dimensions

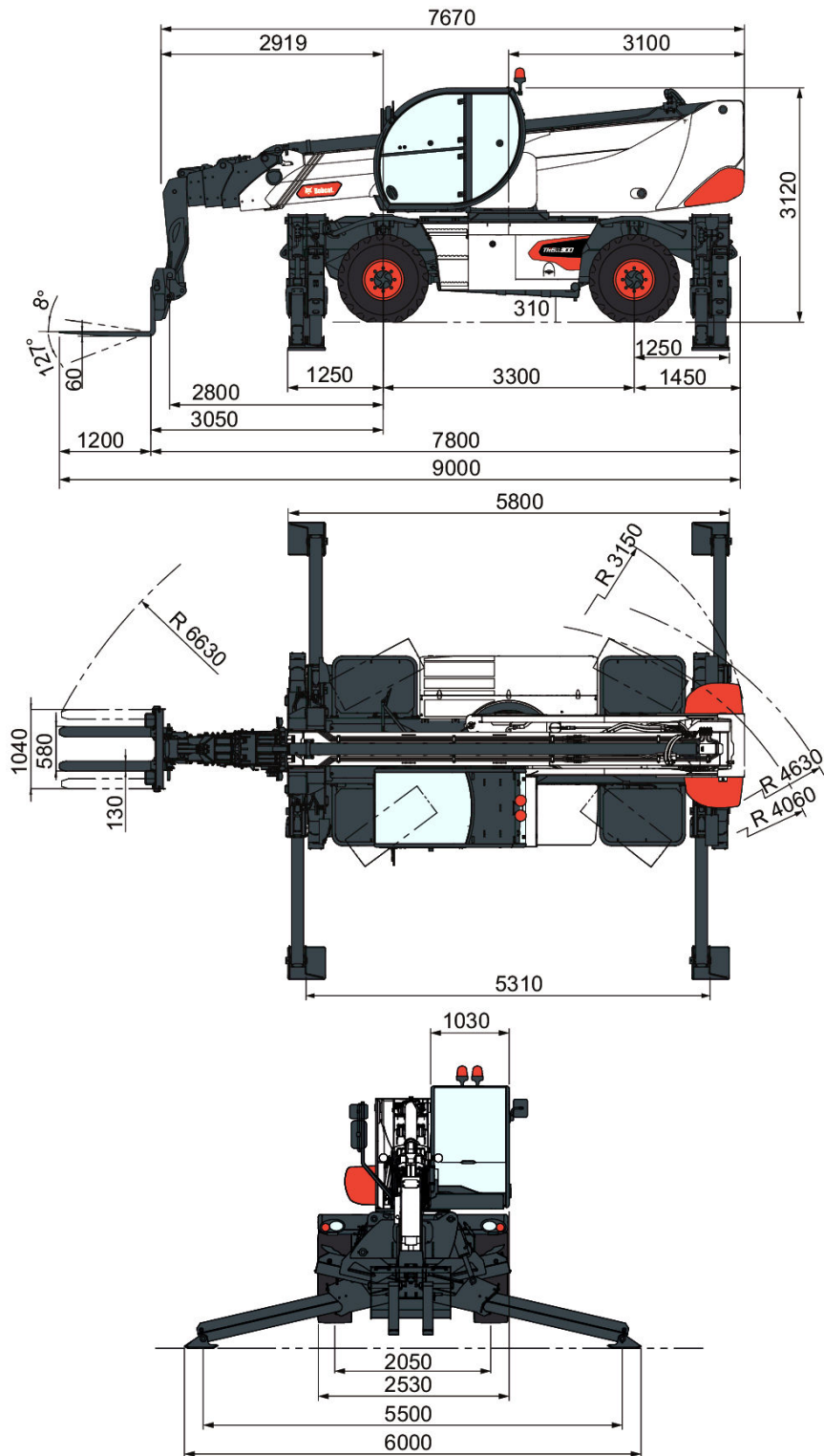

Load Charts

360° LOAD CHART
ON FULLY EXTENDED STABILIZERS

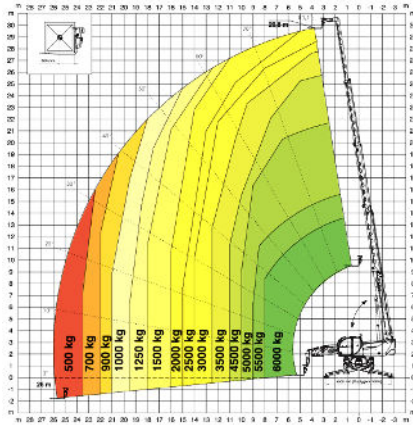

FRONTAL LOAD CHART ON TYRES

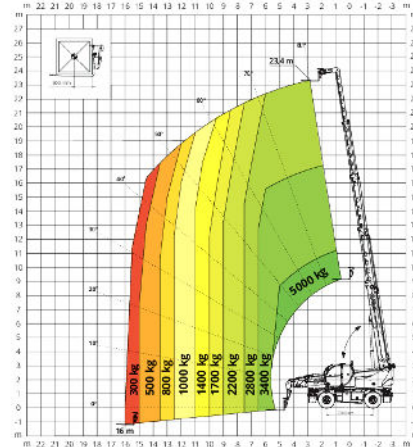

WINCH 3,500 kg

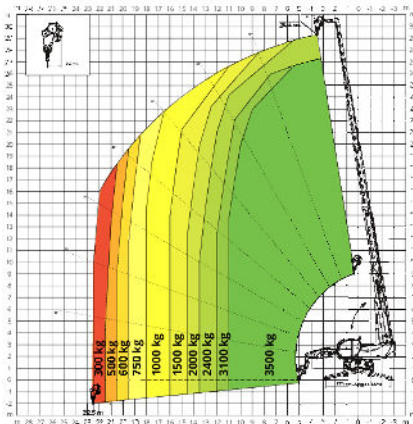

WINCH 6,000 kg

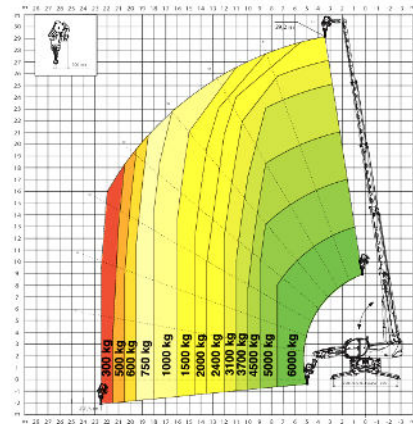

JIB WITH WINCH 800 kg



JIB WITH WINCH 1,500 kg

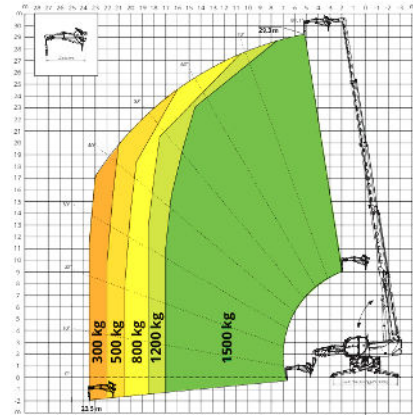

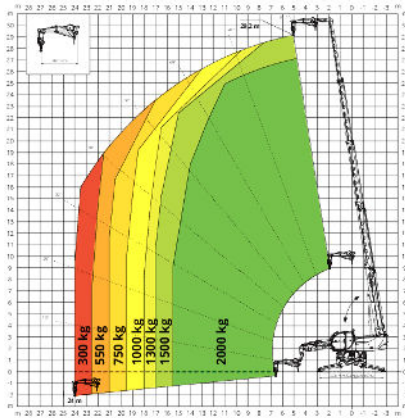
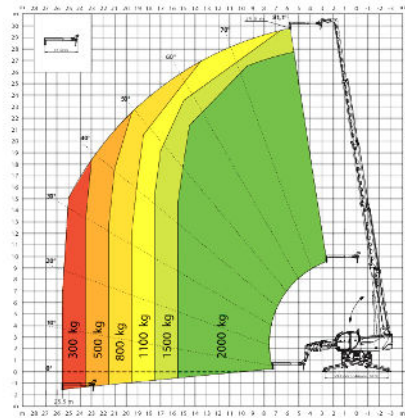
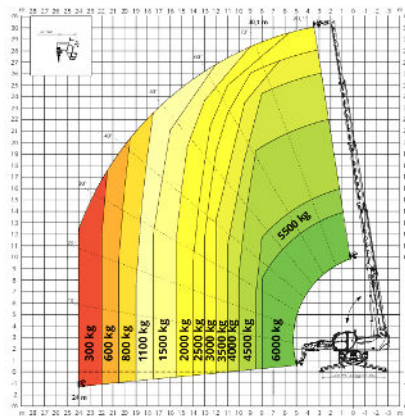
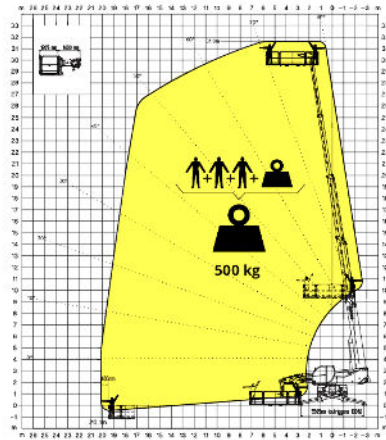
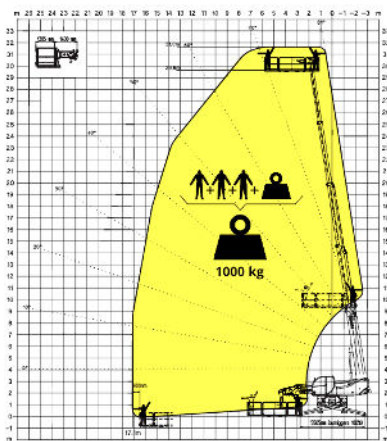
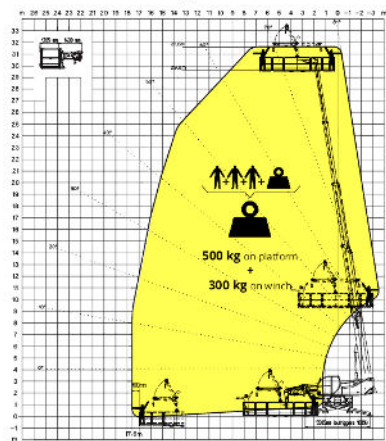
Load Charts
JIB WITH WINCH 2,000 kg

JIB 2,000 kg

HOOK 6,000 kg

ROTATING EXTENDABLE BASKET 500 kg

ROTATING EXTENDABLE BASKET 1,000 kg

**BASKET 6.5 m 500 kg
WITH WINCH 300 kg**

Performance

Rated capacity	6,000 kg @ 600 mm Load Center
Max. lifting height (stabilisers fully extended)	30 m
Capacity at max. height (stabilisers fully extended)	2500 kg
Max. reach (stabilisers fully extended)	26 m
Capacity at max. reach (stabilisers fully extended)	500 kg
Frame levelling	+/- 8°
Max. speed	40.0 km/h
Turret Rotation	360° (Continuous)

Stabilisers

Type	Telescopic scissors
Stabilization system	Ground pressure detection. Automatic levelling. Lifting capacity adjusted in proportion to stabiliser extension
Stabilization area (stabilisers fully extended)	5.80 x 6.0 m

Weights

Weight (unladen)	21800 kg
Front axle weight unladen (boom retracted and lowered)	9800 kg
Rear axle weight unladen (boom retracted and lowered)	12000 kg

Engine

Make / Model	Volvo TAD 582 VE
Compliance	Stage V
Fuel	Diesel
Cooling	liquid - Intercooler
Rated power (ISO 14396)	160 kW (218 hp) @ 2,300 rpm
Maximum torque	925 Nm @ 1,380 rpm
Number of cylinders	4.0
Displacement	5.13 L

Hydraulic System

Pump type	Load Sensing pump
Pump capacity	160.00 L/min
Output at the auxiliary line	65.00 L/min
Relief valve pressure setting	350.00 bar
Control valve (boom and turret)	Electro-proportional with flow sharing

Drive System

Transmission	Hydrostatic with electronic regulation / 4 wheel drive
Main drive	Electronically controlled variable displacement pump. Variable displacement motor. 2-speed gear box

Traction

Standard tyres	445/65 R22,5
Max. speed at Low range (turtle)	11.0 km/h
Max. speed at High range (rabbit)	40.0 km/h
Towing force	95.00 kN
Gradeability	44.00 %

Axles and brakes

Axle type	Oil-immersed axles with planetary gears
Rear axle	Oscillating and steering with hydraulic locking
Front axle	Oscillating and steering with levelling +/-8°
Service brake	Hydraulically operated wet multi-disk brakes on each axle
Parking brake	Hydraulic with negative action
Emergency brake	Passive brake with automatic actuation

Steering

Steering modes	3 steering modes with semi-automatic wheel realignment. 2 wheel steering / 4 wheel steering / Crab-steer
External turning radius (with forks)	4 m

Fluid Capacities

Fuel tank	270.00 L
Adblue	40.00 L
Hydraulic reservoir	195.00 L
Engine oil	16.00 L
Cooling system	40.00 L

Environmental

Operator noise level (LpA) (En 12053)	73 dB(A)
Level of acoustic power (LWA)	108 dB(A)
Whole body vibration (ISO 2631-1):	0.62 ms ⁻²
Hand-arm vibration (ISO 5349-1)	0.52 ms ⁻²

Standards

Standard compliance	EN 1459-2: slewing variable-reach trucks. EN 13000: hydraulic cranes. EN 280: mobile elevating work platforms. FOPS/ROPS cabin. EU 2016/1628: engine emissions
---------------------	--

Standard Features

Standard Features

- Frame and Telescopic boom:
 - Quick fit carriage with manual attachment lock
 - Pallet Fork Frame Floating, 1,3m wide, Forks included
 - Auxiliary hydraulic line on boom head and return line to hydraulic tank
 - Automatic RFID tools recognition system
 - Man platform ready and electric emergency pump
 - Winch ready
 - Heavy duty axles with epicyclic reduction gears, oil immerse brakes
 - Rear axles oscillating and steering with hydraulic locking
 - Towing hook
 - Frame leveling +/-8°
 - Complete road lights (front & rear)
 - Right and left side mirrors
 - *****
- Cabin and main functions:
 - Cabin with full glass window door
 - Full tinted glass
 - Pressurized Cab, 100% air filtration
 - ROPS/FOPS operator cabin
 - Automatic parking brake
 - Roof window wiper
 - Front wipers with washer
 - Rotating beacon
 - Adjustable steering column
 - Heating, demisting and ventilation
 - Air conditioning (HVAC)
 - Back-up alarm
 - Bluetooth radio, microphone & loudspeakers
 - Mechanical Suspension Seat
 - 10" touch screen
 - Jog shuttle
 - Two multifunctional joysticks with proportional controls and forward/reverse drive
 - Load moment control system with dynamic load chart on touchscreen display
 - Auto idle
 - Autoleveling system on stabilisers
 - 3 steering modes (2WS /4WS / CRAB) with semi-automatic wheel realignment
 - Rear axle lock indicator
 - Front and rear wheels alignment indicator
 - 24V Electric socket
 - CAN Bus technology with auto-diagnostic system
 - *****
- Drive/Engine/Hydraulic:
 - Electro proportional main valve with flow sharing
 - High precision slewing drive
 - Hydrostatic transmission with electronically controlled variable displacement pump Variable displacement motor 2-speed gear box (turtle/rabbit)
 - 40 km/h max drive speed
 - Standard tyres - set of 4 x 445/65 R22,5"
 - Turbo-charged engine - Volvo TAD 582 VE Stage V - 218hp / 925Nm
 - Battery Disconnection (inside engine compartment)
 - *****
 - 2 year warranty or 2000 hours (refer to the Bobcat standard warranty policy for terms and conditions)
 - Telemetry system